

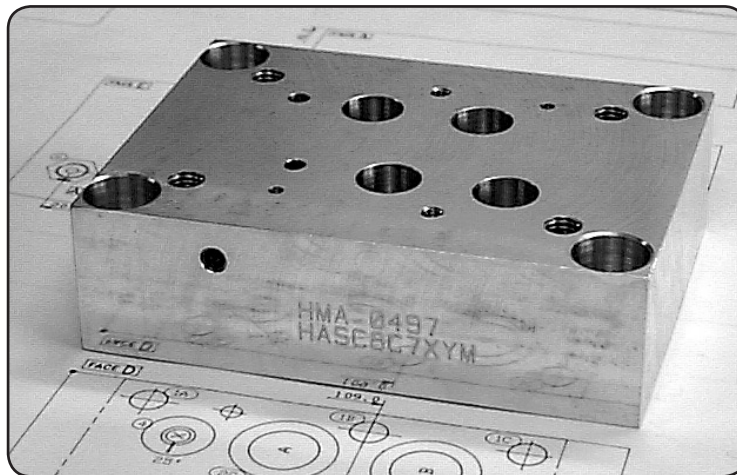

HASC8C7XY* Adaptor Sandwich - Cetop8 to Cetop7

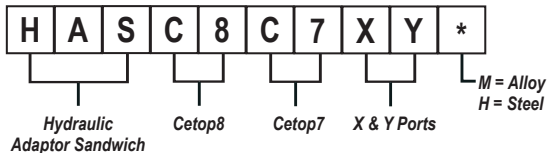

Specifications

Material :	Alloy 6061-T6	Steel - S1214
Max. Working Pressure :	Alloy - 210 Bar	Steel - 350 Bar
Surface Treatment :	Alloy - Nil	Steel - Zinc Gold Passivation

Included Components

Socket Head Cap Screws :	4 each M12 x 40
O-Rings :	4 each N9-121 , 3 each N9-114

Technical Details

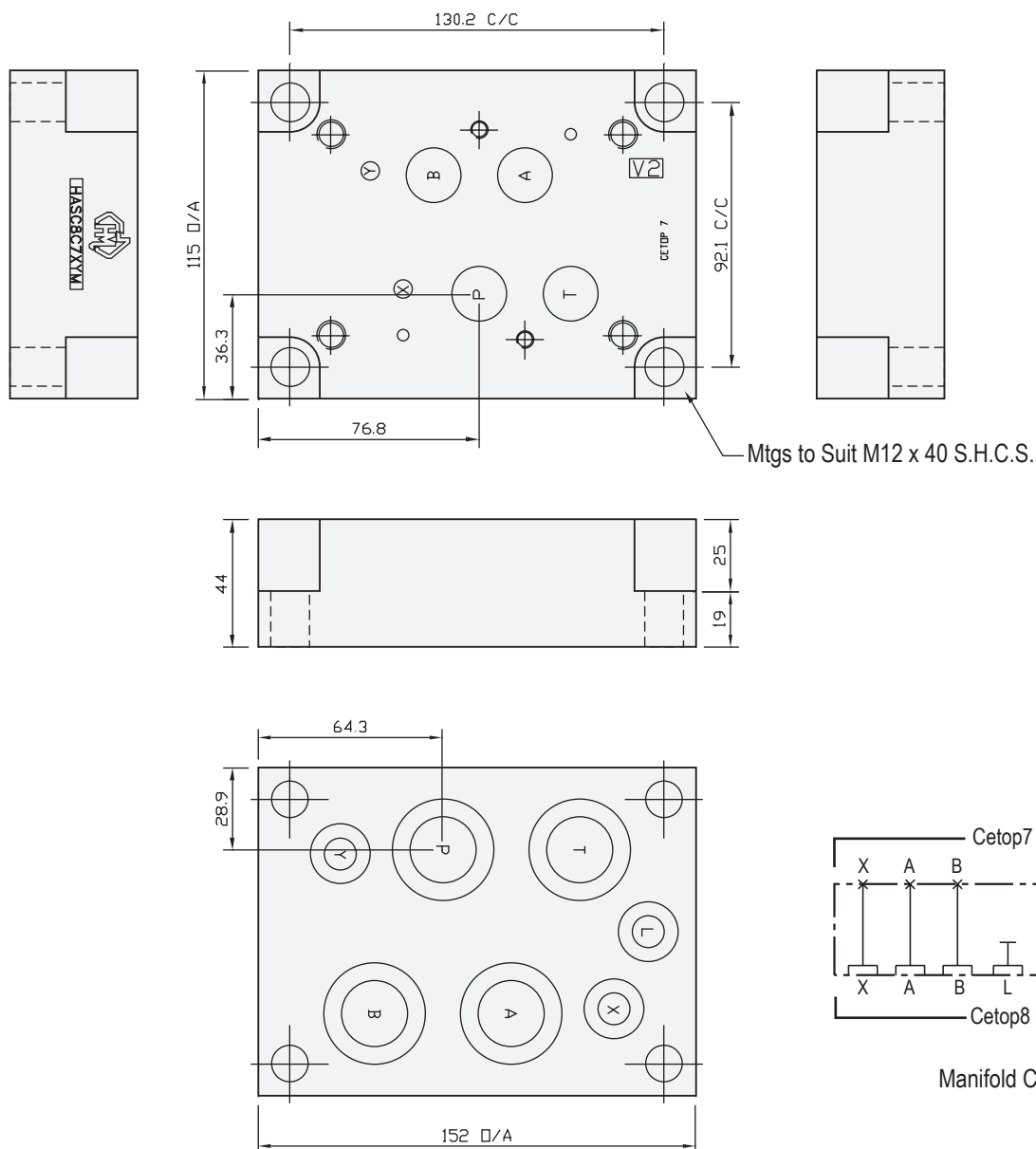

CETOP 8

Projection



Part Number	Nominal Mass Kg
HASC8C7XYH	10.0
HASC8C7XYM	2.0