

HASC10C8XY* ADAPTOR SANDWICH

Cetop10 to Cetop8 - X & Y - Ports

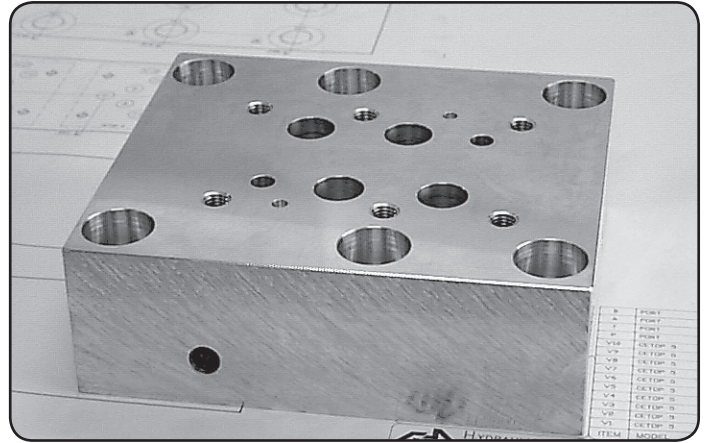

CETOP 10

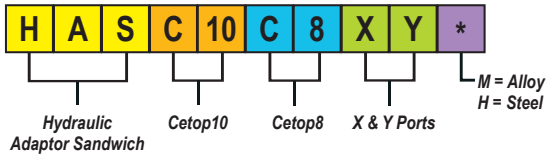

Specifications

Material :	Alloy 6061-T6	Steel - S1214
Max. Working Pressure :	Alloy - 210 Bar	Steel - 350 Bar
Surface Treatment :	Alloy - Nil	Steel - Zinc Gold Passivation

Included Components

Socket Head Cap Screws :	6 each M20 x 65
O-Rings :	4 each N9-220 , 3 each N9-210

Technical Details

6 Mtgs to Suit M20 x 65 S.H.C.S.

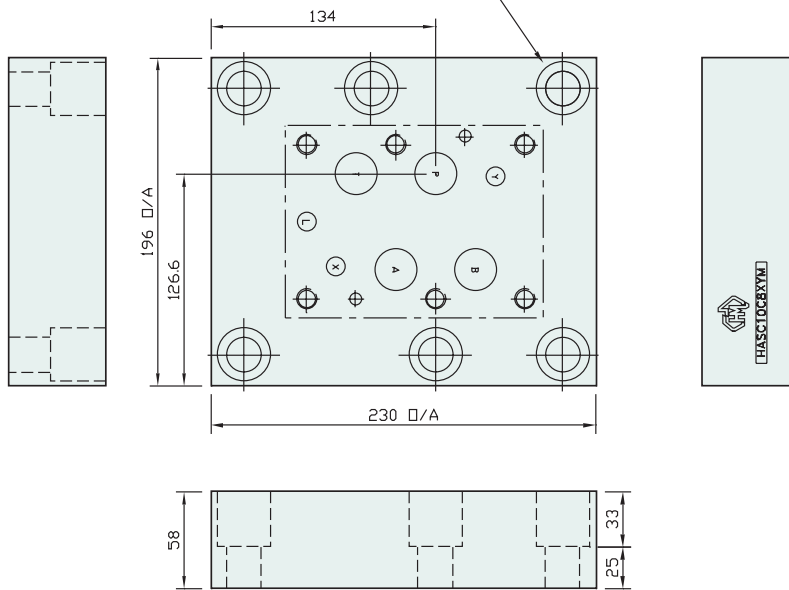

O-Rings to suit 32mm dia. as per ISO Standard 4401

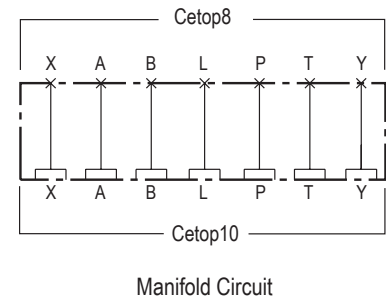
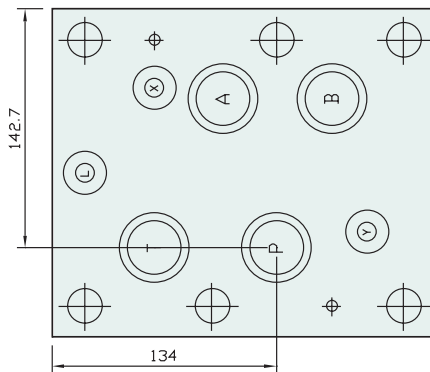

Part Number	Nominal Mass Kg
HASC10C8XYH	18.0
HASC10C8XYM	10.1